

# EMC TEST REPORT



## For Electromagnetic Interference of

Report Reference No. ....:	E01A22030783E00101
Engineer (name + signature) .....	Duke Liu
Reviewed by (name + signature) .....	Tiger Xu
Approved by (name + signature).....:	Alan He
Date of Receipt of EUT .....	Jan. 24, 2022
Date of Test .....	Jan. 24, 2022 to Feb. 08, 2022
Date of Issue .....	Apr. 02, 2022
Testing Laboratory.....:	Dongguan Anci Electronic Technology Co., Ltd.
Address .....	1-2 Floor, Building A, No.11, Headquarters 2 Road, Songshan Lake Hi-tech Industrial Development Zone, Dongguan City, Guangdong, China
Laboratory location.....:	EMC Laboratory
Applicant's name .....	Shenzhen Chooship Co., Ltd.
Address .....	4th Floor, N+ Chuanghui Building, NO. 15 Tian'an Road, Bantian Zone, Longgang District, Shenzhen City, Guangdong Province, China
Manufacturer .....	Huizhou JETECH Energy Technology Co., Ltd.
Address .....	No.65 Lizhen, Egongzui Group, Panli village, Lilin Town, Zhongkai High-Tech Zone, Huizhou. P. R. China
Factory's name.....:	Huizhou JETECH Energy Technology Co., Ltd.
Address.....:	No.65 Lizhen, Egongzui Group, Panli village, Lilin Town, Zhongkai High-Tech Zone, Huizhou. P. R. China



**Test specification:**

EUT description.....	Lithium-Ion Battery
Trade Mark .....	N/A
Model/Type reference .....	20S4P 73.6V
Test Sample.....	20S4P 73.6V
Ratings .....	73.6V/6.4Ah/471.04Wh, 73.6V/10.4Ah/765.44Wh, 73.6V/12.8Ah/942.08Wh, 73.6V/14Ah/1030.4Wh
Tested Power.....	DC 73.6V
Standards .....	EN 55032:2015+A11:2020 EN 55035:2017+A11:2020 EN IEC 61000-3-2:2019+A1:2021 EN 61000-3-3:2013+A1:2019

The device described above was tested by Dong Guan Anci Electronic Technology Co., Ltd. to determine the maximum emission levels emanated from the device and severity levels of the device endure and its performance criterion. The measurement results are contained in this test report and Dong Guan Anci Electronic Technology Co., Ltd. assumes full responsibility for the accuracy and completeness of these measurements. This report shows the EUT is technically compliance with the above official standards.

This report applies to the above sample only and shall not be reproduced in part without written approval of Dong Guan Anci Electronic Technology Co., Ltd.

<b>Table of Contents</b>	<b>Page</b>
<b>1. GENERAL INFORMATION</b>	<b>6</b>
1.1 PRODUCT INFORMATION	6
1.2 Details about the Test Laboratory	7
<b>2. SUMMARY OF TEST RESULTS</b>	<b>9</b>
2.1 MEASUREMENT UNCERTAINTY	10
2.2 DESCRIPTION OF TEST MODES	10
2.3 BLOCK DIGRAM SHOWING THE CONFIGURATION OF SYSTEM TESTED	11
<b>3. EMISSION TEST</b>	<b>12</b>
3.1 CONDUCTED EMISSION MEASUREMENT	12
3.1.1 LIMITS OF CONDUCTED EMISSION(MAINS PORT)	12
3.1.2 MEASUREMENT INSTRUMENTS LIST	12
3.1.3 TEST PROCEDURE	13
3.1.4 DEVIATION FROM TEST STANDARD	13
3.1.5 TEST SETUP	14
3.1.6 EUT OPERATING CONDITIONS	14
3.1.7 TEST RESULTS	14
3.2 RADIATED EMISSION MEASUREMENT	15
3.2.1 LIMITS OF RADIATED EMISSION MEASUREMENT	15
3.2.2 MEASUREMENT INSTRUMENTS LIST	15
3.2.3 TEST PROCEDURE	16
3.2.4 DEVIATION FROM TEST STANDARD	16
3.2.5 TEST SETUP	16
3.2.6 EUT OPERATING CONDITIONS	16
3.2.7 TEST RESULTS	17
<b>4. IMMUNITY TEST</b>	<b>20</b>
4.1 STANDARD COMPLIANCE/SERVURITY LEVEL/CRITERIA	20
4.2 GENERAL PERFORMANCE CRITERIA	21
4.3 GENERAL PERFORMANCE CRITERIA TEST SETUP	21
4.4 ESD TESTING	22
4.4.1 TEST SPECIFICATION	22
4.4.2 MEASUREMENT INSTRUMENTS	22
4.4.3 TEST PROCEDURE	22
4.4.4 DEVIATION FROM TEST STANDARD	23
4.4.5 TEST SETUP	23
4.4.6 TEST RESULTS	24

<b>Table of Contents</b>	<b>Page</b>
4.5 RS TESTING	25
4.5.1 TEST SPECIFICATION	25
4.5.2 MEASUREMENT INSTRUMENTS	25
4.5.3 TEST PROCEDURE	25
4.5.4 DEVIATION FROM TEST STANDARD	25
4.5.5 TEST SETUP	26
4.5.6 TEST RESULTS	27
4.6 EFT/BURST TESTING	28
4.6.1 TEST SPECIFICATION	28
4.6.2 MEASUREMENT INSTRUMENTS	28
4.6.3 TEST PROCEDURE	28
4.6.4 DEVIATION FROM TEST STANDARD	28
4.6.5 TEST SETUP	29
4.6.6 TEST RESULTS	29
4.7 SURGE TESTING	30
4.7.1 TEST SPECIFICATION	30
4.7.2 MEASUREMENT INSTRUMENTS	30
4.7.3 TEST PROCEDURE	30
4.7.4 DEVIATION FROM TEST STANDARD	30
4.7.5 TEST SETUP	31
4.7.6 TEST RESULTS	31
4.8 INJECTION CURRENT TESTING	32
4.8.1 TEST SPECIFICATION	32
4.8.2 MEASUREMENT INSTRUMENTS	32
4.8.3 TEST PROCEDURE	32
4.8.4 DEVIATION FROM TEST STANDARD	32
4.8.5 TEST SETUP	33
4.8.6 TEST RESULTS	33
4.9 VOLTAGE INTERRUPTION/DIPS TESTING	34
4.9.1 TEST SPECIFICATION	34
4.9.2 MEASUREMENT INSTRUMENTS	34
4.9.3 TEST PROCEDURE	34
4.9.4 DEVIATION FROM TEST STANDARD	34
4.9.5 TEST SETUP	35
4.9.6 TEST RESULTS	35
4.10 POWER-FREQUENCY MAGNETIC FILDS	36
4.10.1 MEASUREMENT INSTRUMENTS	36
4.10.2 TEST LEVEL AND PERFORMANCE CRITERION	36
4.10.3 TEST PROCEDURE	36

<b>Table of Contents</b>	<b>Page</b>
4.10.4 DEVIATION FROM TEST STANDARD	36
4.10.5 TEST SETUP	37
4.10.6 TEST RESULTS	37
5. ATTACHMENT	38
5.1 EUT TEST PHOTO	38
5.2 EUT PHOTO	39

## **1. GENERAL INFORMATION**

### **1.1 PRODUCT INFORMATION**

The product is Lithium-Ion Battery for use with information technology equipment.

All tests was performed on model 20S4P 73.6V.

The EUT passed the test.

**1.2 Details about the Test Laboratory****Test Site 1:**

Company name: Dongguan Anci Electronic Technology Co., Ltd.

Address: 1-2 Floor, Building A, No.11, Headquarters 2 Road, Songshan Lake  
Hi-tech Industrial Development Zone, Dongguan City,  
Guangdong Pr., China.

Telephone: +86-769- 8507 5888

Fax: +86-769- 8507 5898

**Test Site 2:**

Company name: Guangdong Dongguan Quality Supervision Testing Center

Address: No.2 South Industry Road, Dongguan Songshan Lake  
Sci.&Tech. Industrial Park, Guangdong Province, China

Telephone: +86 769 2307 1111

Fax: +86 769 2307 7221

Standard	Test Item	Test Site
EN 55032:2015+A11:2020	Conducted Emission	N/A
	Radiated Emission Below 1 GHz	1
	Radiated Emission Above 1 GHz	N/A
EN IEC 61000-3-2:2019+A1:2021	Harmonic Current Emission	N/A
EN 61000-3-3:2013+A1:2019	Voltage Fluctuations & Flicker	N/A
EN 61000-4-2:2009	Electrostatic Discharge	1
EN 61000-4-3:2006+A1:2008+A2:2010	RF electromagnetic field	2
EN 61000-4-4:2012	Fast transients	N/A
EN 61000-4-5:2014+A1:2017	Surges	N/A
EN 61000-4-6:2014	Injected Current	N/A
EN 61000-4-8:2010	Power Frequency Magnetic Field	N/A
EN 61000-4-11:2004	Volt. Interruptions Volt. Dips	N/A



## 2. SUMMARY OF TEST RESULTS

Test procedures according to the technical standards:

Emission				
Standard	Test Item	Limit	Judgment	Remark
EN 55032:2015+A11:2020	Conducted Emission	Class B	N/A	
	Radiated Emission Below 1 GHz	Class B	PASS	
	Radiated Emission Above 1 GHz	Class B	N/A	NOTE (1) NOTE (4)
EN IEC 61000-3-2:2019+A1:2021	Harmonic Current Emission	Class A	N/A	
EN 61000-3-3:2013+A1:2019	Voltage Fluctuations & Flicker	Clause 5	N/A	
Immunity (EN 55035:2017+A11:2020)				
Section	Test Item	Performance Criteria	Judgment	Remark
EN 61000-4-2:2009	Electrostatic Discharge	B	PASS	
EN 61000-4-3:2006 +A1:2008+A2: 2010	RF electromagnetic field	A	PASS	
EN 61000-4-4:2012	Fast transients	B	N/A	
EN 61000-4-5:2014+A1:2017	Surges	B	N/A	
EN 61000-4-6:2014	Injected Current	A	N/A	
EN 61000-4-8:2010	Power Frequency Magnetic Field	A	N/A	
EN 61000-4-11:2004	Volt. Interruptions Volt. Dips	B / C / C <b>NOTE (3)</b>	N/A	

**NOTE:**

- (1) "N/A" denotes test is not applicable in this Test Report
- (2) The power consumption of EUT is less than 75W and no Limits apply.
- (3) Voltage dip: >95% reduction – Performance Criteria B  
Voltage dip: 30% reduction – Performance Criteria C  
Voltage Interruption: >95% reduction – Performance Criteria C
- (4) If the highest frequency of the internal sources of the EUT is less than 108 MHz, the measurement shall only be made up to 1 GHz. If the highest frequency of the internal sources of the EUT is between 108 MHz and 500 MHz, the measurement shall only be made up to 2GHz. If the highest frequency of the internal sources of the EUT is between 500 MHz and 1GHz, measurement shall only be made up to 5 GHz. If the highest frequency of the internal sources of the EUT is above 1 GHz, the measurement shall be made up to 5 times the highest frequency or 40 GHz, whichever is less.

**2.1 MEASUREMENT UNCERTAINTY**

The reported uncertainty of measurement  $y \pm U$ , where expanded uncertainty  $U$  is based on a standard uncertainty multiplied by a coverage factor of  $k=2$ , providing a level of confidence of approximately 95 %.

A. Radiated Measurement :

Test Site	Method	Measurement Frequency Range	Ant. H / V	U (dB)	NOTE
S02	ANSI	30MHz ~ 200MHz	V	3.69	
S02	ANSI	30MHz ~ 200MHz	H	3.69	
S02	ANSI	200MHz ~ 1000MHz	V	3.67	
S02	ANSI	200MHz ~ 1000MHz	H	3.67	

**2.2 DESCRIPTION OF TEST MODES**

To investigate the maximum EMI emission characteristics generates from EUT, the test system was pre-scanning tested base on the consideration of following EUT operation mode or test configuration mode which possible have effect on EMI emission level. Each of these EUT operation mode(s) or test configuration mode(s) mentioned above was evaluated respectively.

For Emission Test	
Test Mode	Description
Mode	Discharging

For Immunity Test	
Test Mode	Description
Mode	Discharging

2.3 BLOCK DIGRAM SHOWING THE CONFIGURATION OF SYSTEM TESTED

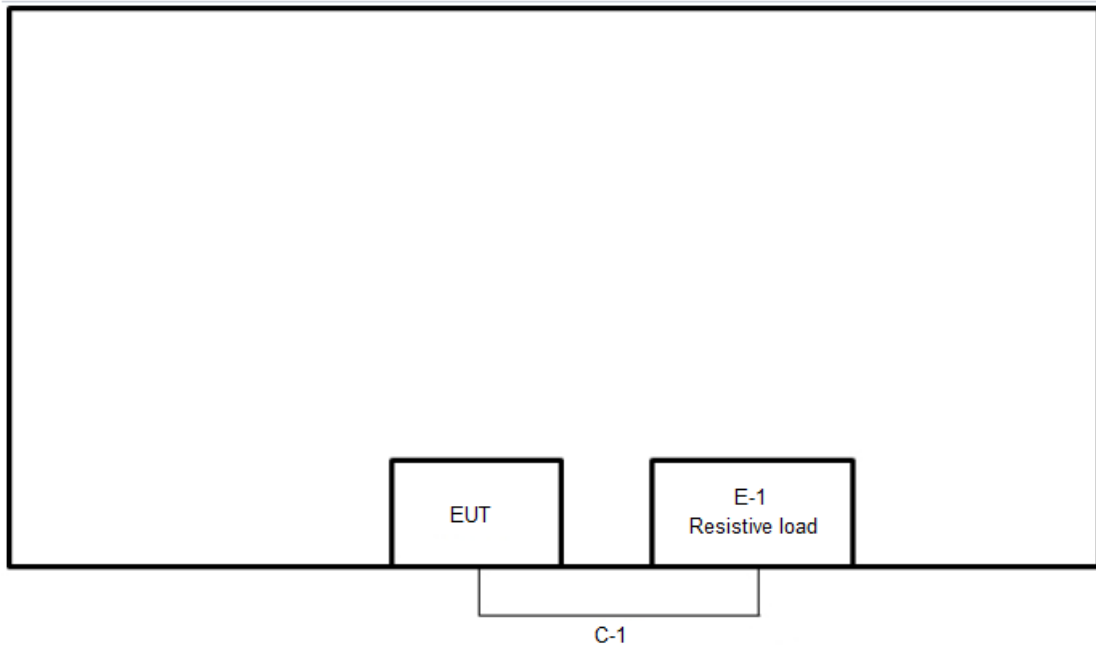

The EUT has been tested as an independent unit together with other necessary accessories or support units. The following support units or accessories were used to form a representative test configuration during the tests.

Item	Equipment
E-1	Resistance

Item	Type of cable
C-1	DC Cable

### 3. EMISSION TEST

#### 3.1 CONDUCTED EMISSION MEASUREMENT

##### 3.1.1 LIMITS OF CONDUCTED EMISSION(MAINS PORT) (Frequency Range 150KHz-30MHz)

FREQUENCY (MHz)	Class A (dBuV)		Class B (dBuV)	
	Quasi-peak	Average	Quasi-peak	Average
0.15 -0.5	79.00	66.00	66 - 56 *	56 - 46 *
0.50 -5.0	73.00	60.00	56.00	46.00
5.0 -30.0	73.00	60.00	60.00	50.00

Note:

- (1) The tighter limit applies at the band edges.
- (2) The limit of " \* " marked band means the limitation decreases linearly with the logarithm of the frequency in the range.
- (3) The test result calculated as following:

Measurement Value = Reading Level + Correct Factor

Correct Factor = Insertion Loss + Cable Loss + Attenuator Factor (if use)

Margin Level = Measurement Value - Limit Value

The following table is the setting of the receiver

Receiver Parameters	Setting
Attenuation	10 dB
Start Frequency	0.15 MHz
Stop Frequency	30 MHz
IF Bandwidth	9 kHz

##### 3.1.2 MEASUREMENT INSTRUMENTS LIST

Item	Instr.Code	Kind of Equipment	Manufacturer	Type No.	Serial No.	Calibrated until
1	AN-E010	L.I.S.N	SCHWARZBECK	NSLK 8127	8127-669	2022-05-20
2	AN-E028	TRANSIENT LIMITER	CYBERTEK	EM5010A	E1950100113	2022-05-20
3	AN-E022	RF Cable	N/A	ZT06S-BNCJ-NJ-7.5M	19044020	2022-05-20
4	AN-E020	EMI Test Receiver	ROHDE&SCHWARZ	ESCI	101358	2022-05-20
5	AN-E058	1# Shielded Room	chengyu	8m*4m*3.3m	N/A	2022-05-06
6	AN-E046	Test Software	Farad	EZ-EMC Ver:ANCI-8A1	N/A	N/A

Remark: " N/A " denotes No Model No. , Serial No. or No Calibration specified.

### 3.1.3 TEST PROCEDURE

- a. The EUT was placed 0.4 meters from the horizontal ground plane with EUT being connected to the power mains through a line impedance stabilization network (LISN). All other support equipments powered from additional LISN(s). The LISN provide 50 Ohm/ 50uH of coupling impedance for the measuring instrument.
- b. Interconnecting cables that hang closer than 40 cm to the ground plane shall be folded back and forth in the center forming a bundle 30 to 40 cm long.
- c. I/O cables that are not connected to a peripheral shall be bundled in the center. The end of the cable may be terminated, if required, using the correct terminating impedance. The overall length shall not exceed 1 m.
- d. LISN at least 80 cm from nearest part of EUT chassis.
- e. For the actual test configuration, please refer to the related Item –EUT Test Photos.

### 3.1.4 DEVIATION FROM TEST STANDARD

No deviation

### 3.1.5 TEST SETUP

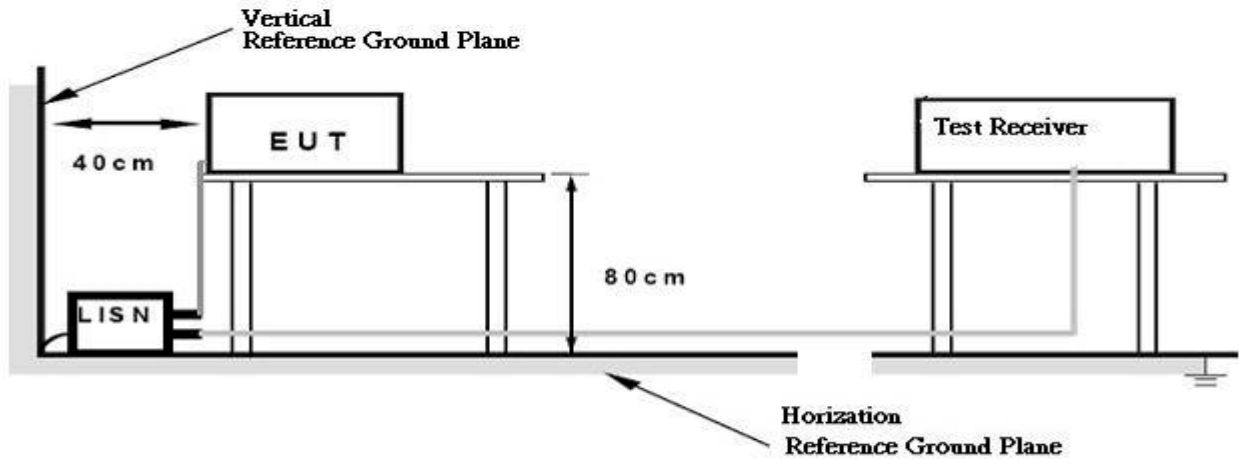

### 3.1.6 EUT OPERATING CONDITIONS

The EUT exercise program used during radiated and/or conducted emission measurement was designed to exercise the various system components in a manner similar to a typical use.

### 3.1.7 TEST RESULTS

No applicable the DC product.

### 3.2 RADIATED EMISSION MEASUREMENT

#### 3.2.1 LIMITS OF RADIATED EMISSION MEASUREMENT (Below 1000MHz)

FREQUENCY (MHz)	Class A (at 3m)	Class B (at 3m)
	dBuV/m	dBuV/m
30 – 230	50	40
230 – 1000	57	47

Notes:

- (1) The limit for radiated test was performed according to as following:  
EN 55032/CISPR 32.
- (2) The tighter limit applies at the band edges.
- (3) Emission level (dBuV/m)=20log Emission level (uV/m).

#### LIMITS OF RADIATED EMISSION MEASUREMENT (Above 1000MHz)

FREQUENCY (GHz)	Class A (dBuV/m) (at 3m)		Class B (dBuV/m) (at 3m)	
	PEAK	AVERAGE	PEAK	AVERAGE
1 ~ 3	76	56	70	50
3 ~ 6	80	60	74	54

Notes:

- (1) The limit for radiated test was performed according to EN 55032/CISPR 32.
- (2) The tighter limit applies at the band edges.
- (3) Emission level (dBuV/m)=20log Emission level (uV/m).

#### 3.2.2 MEASUREMENT INSTRUMENTS LIST

##### 3m Radiated Emission Measurement 30MHz-1GHz

Item	Instr.Code	Kind of Equipment	Manufacturer	Type No.	Serial No.	Calibrated until
1	AN-E023	EMI Test Receiver	Rohde & Schwarz	ESPI	100502	2022-11-11
2	AN-E006	Pre-Amplifier	HP	8447D	2727A06172	2022-05-20
3	AN-E009	Bilog Antenna	Schwarzbeck	VULB9163	VULB9163-588	2022-05-21
4	AN-E033	RF Cable	N/A	ZT06S-NJ-NJ-11M	04040071-VI	2022-05-20
5	AN-E007	RF Cable	N/A	ZT06S-NJ-NJ-0.5M	1007290	2022-05-20
6	AN-E043	3m Semi-anechoic Chamber	chengyu	9m*6m*6m	N/A	2023-11-11
7	AN-E045	Test Software	Farad	EZ-EMC Ver:ANCI-3A1	N/A	N/A

Remark: " N/A" denotes No Model No. / Serial No. and No Calibration specified.

**3.2.3 TEST PROCEDURE**

- a. The measuring distance of at 3m or 10 m shall be used for measurements at frequency up to 1GHz. For frequencies above 1GHz, any suitable measuring distance may be used.
- b. The EUT was placed on the top of a rotating table 0.8 meters above the ground at a 3m or 10 meter open area test site. The table was rotated 360 degrees to determine the position of the highest radiation.
- c. The height of the equipment or of the substitution antenna shall be 0.8 m; the height of the test antenna shall vary between 1 m to 4 m. Both horizontal and vertical polarizations of the antenna are set to make the measurement.
- d. The initial step in collecting conducted emission data is a spectrum analyzer peak detector mode pre-scanning the measurement frequency range. Significant peaks are then marked and then Quasi Peak detector mode re-measured.
- e. If the Peak Mode measured value compliance with and lower than Quasi Peak Mode Limit, the EUT shall be deemed to meet QP Limits and then no additional QP Mode measurement performed.
- f. For the actual test configuration, please refer to the related Item –EUT Test Photos.

**3.2.4 DEVIATION FROM TEST STANDARD**

No deviation

**3.2.5 TEST SETUP**

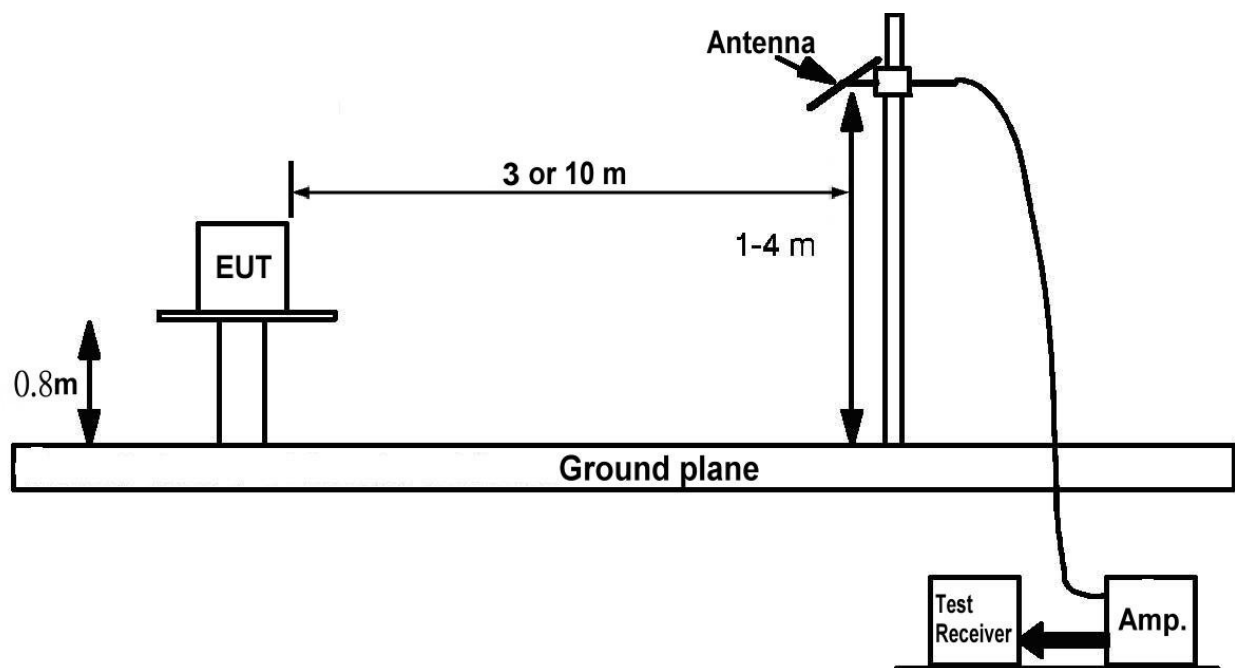

**3.2.6 EUT OPERATING CONDITIONS**

The EUT tested system was configured as the statements of 3.1.6 Unless otherwise a special operating condition is specified in the follows during the testing.



**3.2.7 TEST RESULTS**

<b>EUT:</b>	Lithium-Ion Battery	<b>Model No.:</b>	20S4P 73.6V
<b>Temperature:</b>	24.3°C	<b>Relative Humidity:</b>	53.2%
<b>Pressure:</b>	1008 hPa	<b>Test Power :</b>	DC 73.6V
<b>Test Mode :</b>	Discharging		

Remark :

- (1) Reading in which marked as QP or Peak means measurements by using are Quasi-Peak Detector or Peak Detector.
- (2) All readings are Peak unless otherwise stated QP in column of 『Note』 . Peak denotes that the Peak reading compliance with the QP Limits and then QP Mode measurement didn't perform.
- (3) Measuring frequency range from 30MHz to 1000MHz.
- (4) If the peak scan value lower limit more than 20dB, then this signal data does not show in table.

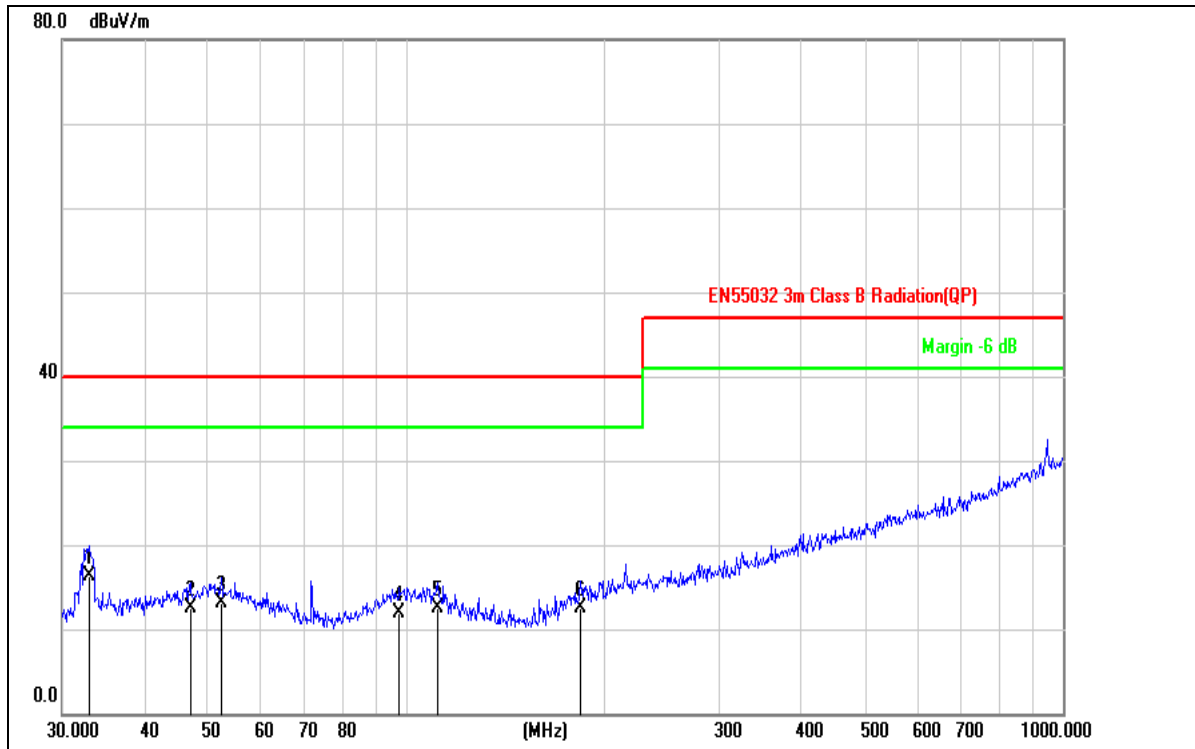

<b>Site:</b> LAB	<b>Antenna:</b> Vertical	<b>Temperature(C):</b> 24.3(C)
<b>Limit:</b> EN55032 3m Class B Radiation(QP)		<b>Humidity(%):</b> 53.2%
<b>EUT:</b> Lithium-Ion Battery	<b>Test Time:</b> 2022/02/08	
<b>M/N.:</b> 20S4P 73.6V	<b>Power Rating:</b> DC 73.6V	
<b>Mode:</b> Discharging	<b>Test Engineer:</b> Bast	
<b>Note:</b>		

No.	Frequency (MHz)	Reading (dBuV)	Factor (dB/m)	Level (dBuV/m)	Limit (dBuV/m)	Margin (dB)	Det.
1	32.9791	30.49	-14.24	16.25	40.00	-23.75	QP
2	46.9948	24.52	-12.10	12.42	40.00	-27.58	QP
3	52.3912	25.04	-11.99	13.05	40.00	-26.95	QP
4	97.7983	23.97	-12.12	11.85	40.00	-28.15	QP
5	111.7380	24.50	-12.04	12.46	40.00	-27.54	QP
6	184.4898	24.49	-11.89	12.60	40.00	-27.40	QP

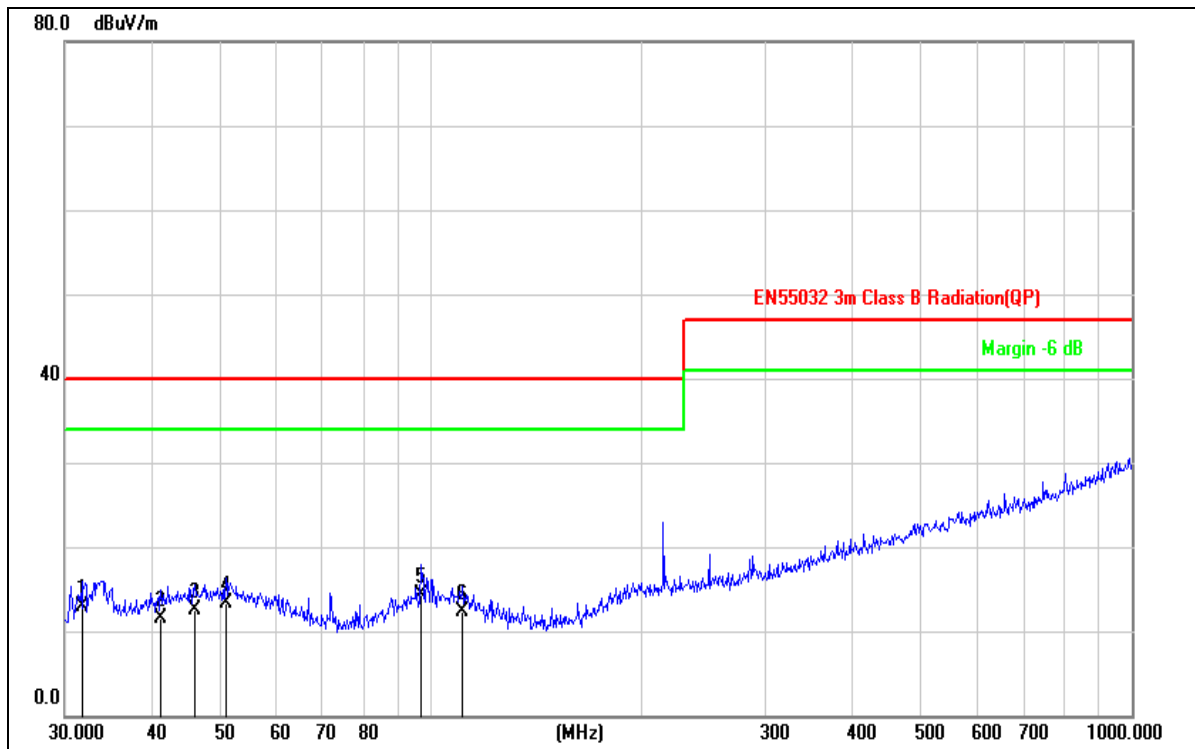

<b>Site:</b> LAB	<b>Antenna::</b> Horizontal	<b>Temperature(C):</b> 24.3(C)
<b>Limit:</b> EN55032 3m Class B Radiation(QP)		<b>Humidity(%):</b> 53.2%
<b>EUT:</b> Lithium-Ion Battery	<b>Test Time:</b>	2022/02/08
<b>M/N.:</b> 20S4P 73.6V	<b>Power Rating:</b>	DC 73.6V
<b>Mode:</b> Discharging	<b>Test Engineer:</b>	Bast
<b>Note:</b>		

No.	Frequency (MHz)	Reading (dBuV)	Factor (dB/m)	Level (dBuV/m)	Limit (dBuV/m)	Margin (dB)	Det.
1	31.8427	27.38	-14.42	12.96	40.00	-27.04	QP
2	41.1320	24.48	-12.96	11.52	40.00	-28.48	QP
3	46.0164	24.70	-12.24	12.46	40.00	-27.54	QP
4	50.9420	25.10	-11.79	13.31	40.00	-26.69	QP
5	96.7749	26.52	-12.29	14.23	40.00	-25.77	QP
6	110.9571	24.13	-11.90	12.23	40.00	-27.77	QP

#### 4. IMMUNITY TEST

##### 4.1 STANDARD COMPLIANCE/SERVRITY LEVEL/CRITERIA

Tests Standard No.	Test Specification	Test Mode Test Ports	Perform. Criteria	Remark
1. ESD IEC/EN 61000-4-2	8KV air discharge 4KV contact discharge	Direct Mode	B	PASS
	4KV HCP discharge 4KV VCP discharge	Indirect Mode	B	PASS
2. RS IEC/EN 61000-4-3	80 MHz to 1000 MHz 3V/m(rms), 1 KHz, 80%, AM modulated	Enclosure	A	PASS
3. EFT/Burst IEC/EN 61000-4-4	1.0KV(peak) 5/50ns Tr/Th 5KHz Repetition Freq.	AC Power Port	B	N/A
	0.5 KV(peak) 5/50ns Tr/Th 5KHz Repetition Freq.	CTL/Signal Data Line Port	B	N/A
4. Surges IEC/EN 61000-4-5	1 KV(5P/5N) 1.2/50(8/20) Tr/Th us	L-N	B	N/A
	2 KV(5P/5N) 1.2/50(8/20) Tr/Th us	L-PE N-PE	B	N/A
5 Injected Current IEC/EN 61000-4-6	0.15 MHz to 80 MHz 3V(rms), 1KHz 80%, AM Modulated 150Ω source impedance	CTL/Signal Port	A	N/A
	0.15 MHz to 80 MHz 3V(rms), 1KHz 80%, AM Modulated 150Ω source impedance	AC Power Port	A	N/A
	0.15 MHz to 80 MHz 3V(rms), 1KHz 80%, AM Modulated 150Ω source impedance	DC Power Port	A	N/A
6. Power Frequency Magnetic Field IEC/EN 61000-4-8	50 Hz, 1A/m	Enclosure	A	N/A
7. Volt. Interruptions Volt. Dips IEC/EN 61000-4-11	Voltage dip > 95% / 30% Interruption > 95%	AC Power Port	B / C C	N/A
				See Remark(2)

\* Remark:

- (1) "N/A": denotes test is not applicable in this Test Report.  
 (2) Voltage dip: >95% reduction – Performance Criteria **B**  
       Voltage dip: 30% reduction – Performance Criteria **C**  
       Voltage Interruption: >95% reduction – Performance Criteria **C**

#### 4.2 GENERAL PERFORMANCE CRITERIA

According to **EN 55035:2017+A11:2020** standard, the general performance criteria as following:

<b>Criterion A</b>	The equipment shall continue to operate as intended without operator intervention. No degradation of performance or loss of function is allowed below a performance level specified by the manufacturer when the equipment is used as intended. The performance level may be replaced by a permissible loss of performance. If the minimum performance level or the permissible performance loss is not specified by the manufacturer, then either of these may be derived from the product description and documentation, and by what the user product description and documentation, and by what the user may reasonably expect from the equipment if used as intended.
<b>Criterion B</b>	After the test, the equipment shall continue to operate as intended without operator Intervention. No degradation of performance or loss of function is allowed, after the application of the phenomenon below a performance level specified by the manufacturer, when the equipment is used as intended. The performance level may be replaced by a permissible loss of performance. During the test, degradation of performance is allowed. However, no change of operating state if stored data allowed to persist after the test. If the minimum performance level (or the permissible performance loss) is not specified by the manufacturer, then either of these may be derived from the product description and documentation, and by what the user may reasonably expect from the equipment if used as intended.
<b>Criterion C</b>	Loss of function is allowed, provided the function is self-recoverable, or can be restored by the operation of the controls by the user in accordance with the manufacturer's instructions. Functions, and/or information stored in non-volatile memory, or protected by a battery backup, shall not be lost.

#### 4.3 GENERAL PERFORMANCE CRITERIA TEST SETUP

The EUT tested system was configured as the statements of **3.1.6** Unless otherwise a special operating condition is specified in the follows during the testing.

#### 4.4 ESD TESTING

##### 4.4.1 TEST SPECIFICATION

<b>Basic Standard:</b>	IEC/EN 61000-4-2
<b>Discharge Impedance:</b>	330 ohm / 150 pF
<b>Required Performance</b>	B
<b>Discharge Voltage:</b>	Air Discharge: 2kV/4kV/8kV (Direct) Contact Discharge: 2kV/4kV (Direct/Indirect)
<b>Polarity:</b>	Positive & Negative
<b>Number of Discharge:</b>	Air Discharge: min. 20 times at each test point Contact Discharge: min. 200 times in total
<b>Discharge Mode:</b>	Contact and Air
<b>Discharge Period:</b>	1 second minimum

##### 4.4.2 MEASUREMENT INSTRUMENTS

Item	Kind of Equipment	Manufacturer	Type No.	Serial No.	Calibrated until
1	ESD Simulator	Prima	ESD61002B	PR13012530	2022-05-21

Remark: " N/A" denotes No Model No. / Serial No. and No Calibration specified.

##### 4.4.3 TEST PROCEDURE

The test generator necessary to perform direct and indirect application of discharges to the EUT in the following manner:

- a. Contact discharge was applied to conductive surfaces and coupling planes of the EUT.
 

During the test, it was performed with single discharges. For the single discharge time between successive single discharges was at least 1 second. The EUT shall be exposed to at least 200 discharges, 100 each at negative and positive polarity, at a minimum of four test points. One of the test points shall be subjected to at least 50 indirect discharges to the center of the front edge of the horizontal coupling plane. The remaining three test points shall each receive at least 50 direct contact discharges.

If no direct contact test points are available, then at least 200 indirect discharges shall be applied in the indirect mode. Test shall be performed at a maximum repetition rate of one discharge per second.

Vertical Coupling Plane (VCP):  
The coupling plane, of dimensions 0.5m x 0.5m, is placed parallel to, and positioned at a distance 0.1m from, the EUT, with the Discharge Electrode touching the coupling plane.  
The four faces of the EUT will be performed with electrostatic discharge.

Horizontal Coupling Plane (HCP):  
The coupling plane is placed under to the EUT. The generator shall be positioned vertically at a distance of 0.1m from the EUT, with the Discharge Electrode touching the coupling plane.  
The four faces of the EUT will be performed with electrostatic discharge.
- b. Air discharges at insulation surfaces of the EUT.
 

It was at least ten single discharges with positive and negative at the same selected point.
- c. For the actual test configuration, please refer to the related Item –EUT Test Photos.

**4.4.4 DEVIATION FROM TEST STANDARD**

No deviation

**4.4.5 TEST SETUP**

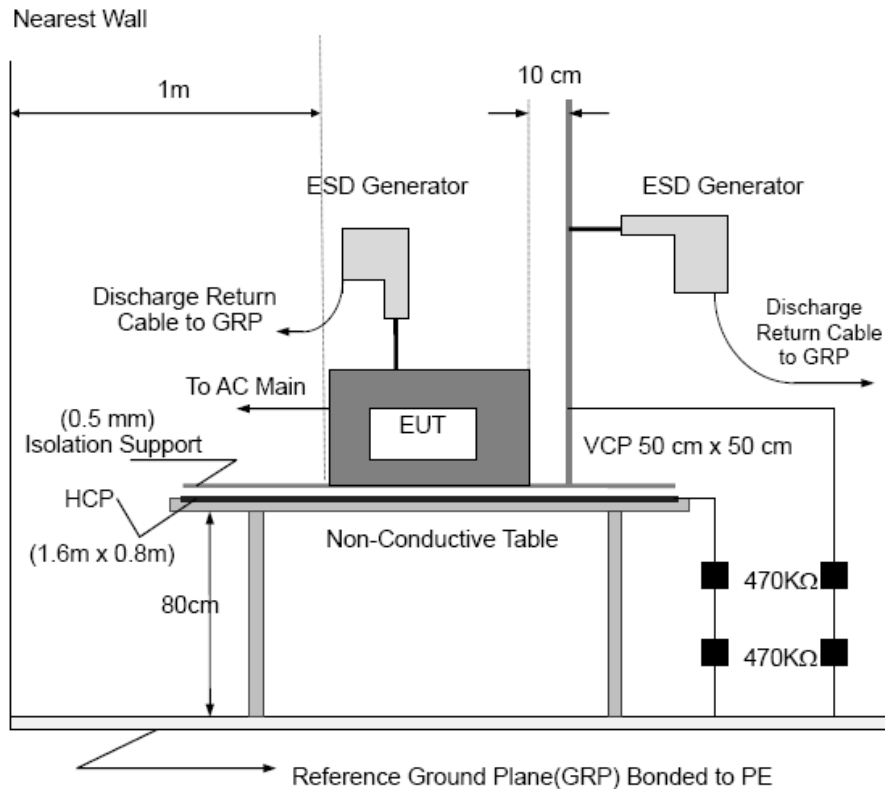

Note:

**TABLE-TOP EQUIPMENT**

The configuration consisted of a wooden table 0.8 meters high standing on the Ground Reference Plane. The GRP consisted of a sheet of aluminum at least 0.25mm thick, and 2.5 meters square connected to the protective grounding system. A Horizontal Coupling Plane (1.6m x 0.8m) was placed on the table and attached to the GRP by means of a cable with 940k total impedance. The equipment under test, was installed in a representative system as described in section 7 of IEC /EN 61000-4-2, and its cables were placed on the HCP and isolated by an insulating support of 0.5mm thickness. A distance of 1-meter minimum was provided between the EUT and the walls of the laboratory and any other metallic structure.

**FLOOR-STANDING EQUIPMENT**

The equipment under test was installed in a representative system as described in section 7 of IEC/EN 61000-4-2, and its cables were isolated from the Ground Reference Plane by an insulating support of 0.1-meter thickness. The GRP consisted of a sheet of aluminum that is at least 0.25mm thick, and 2.5meters square connected to the protective grounding system and extended at least 0.5 meters from the EUT on all sides.

**4.4.6 TEST RESULTS**

Mode	Air Discharge								Contact Discharge							
	2KV		4KV		8KV		12KV		2KV		4KV		6KV		8KV	
Location	P	N	P	N	P	N	P	N	P	N	P	N	P	N	P	N
1	--	--					--	--	A	A	A	A	--	--	--	--
2	--	--	A	A	A	A	--	--					--	--	--	--
3	-	--					--	--	--	--	--	--	--	--	--	--
4	--	--	--	--	--	--	--	--	--	--	--	--	--	--	--	--
5	--	--	--	--	--	--	--	--	--	--	--	--	--	--	--	--
6	-	--	--	--	--	--	--	--	--	--	--	--	--	--	--	--
7	--	--	--	--	--	--	--	--	--	--	--	--	--	--	--	--
8	--	--	--	--	-	--	--	--	--	--	--	--	--	--	--	--
9	--	--	--	--	-	--	--	--	--	--	--	--	--	--	--	--
Criteria	<b>B</b>								<b>B</b>							
Result	<b>A</b>								<b>A</b>							
Judgment	<b>PASS</b>								<b>PASS</b>							

Mode	HCP Discharge								VCP Discharge							
	2KV		4KV		6KV		8KV		2KV		4KV		6KV		8KV	
Location	P	N	P	N	P	N	P	N	P	N	P	N	P	N	P	N
1	-	--	A	A	--	--	--	--	-	--	A	A	--	--	--	--
2	--	--	A	A	--	--	--	--	--	--	A	A	--	--	--	--
3	--	--	A	A	-	--	--	--	--	--	A	A	-	--	--	--
4	-	--	A	A	--	--	--	--	-	--	A	A	--	--	--	--
Criteria	<b>B</b>								<b>B</b>							
Result	<b>A</b>								<b>A</b>							
Judgment	<b>PASS</b>								<b>PASS</b>							

Note:

- 1) P/N denotes the Positive/Negative polarity of the output voltage.
- 2) Test condition:  
 Direct discharges: Minimum 50 times (Positive/Negative) at each point.    Air discharges / Indirect (HCP/VCP): Minimum 20 times (Positive/Negative) at each point.
- 3) Test location(s) in which discharge (Air and contact discharge) to be described as following
- 4) The Indirect (HCP/VCP) discharges description of test point as following:  
 1.left side 2.right side 3.front side 4.rear side
- 5) N/A - denotes test is not applicable in this test report
- 7) Criteria B: The EUT function loss during the test, but self-recoverable after the test.

Test location description:

No	Description	No	Description
1	Each conductive location touchable by hand	3	
2	Each nonconductive location touchable by hand	4	



**4.5 RS TESTING**

**4.5.1 TEST SPECIFICATION**

<b>Basic Standard:</b>	IEC/EN 61000-4-3
<b>Required Performance</b>	A
<b>Frequency Range:</b>	80 MHz - 1000 MHz, 1800, 2600, 3500, 5000 MHz
<b>Field Strength:</b>	3 V/m
<b>Modulation:</b>	1kHz Sine Wave, 80%, AM Modulation
<b>Frequency Step:</b>	1 % of fundamental
<b>Polarity of Antenna:</b>	Horizontal and Vertical
<b>Test Distance:</b>	3 m
<b>Antenna Height:</b>	1.5 m
<b>Dwell Time:</b>	at least 3 seconds

**4.5.2 MEASUREMENT INSTRUMENTS**

Equipment	Manufacturer	Model No.	Serial No.	Next Cal.
Signal Generator	Aglilet	N5171B-50B	MY53050160	2022-11-29
Amplifier	A&R	150W1000M3	313157	2022-08-25
Amplifier	A&R	50SIG6M1	0342835	2022-08-25
Power Meter	Boonton	4232A	15102	2022-08-11
Isotropic Field Probe	A&R	FL7006	0342652	2022-10-24
Log-periodic Antenna	SCHWARZBECK	STLP 9128E	9128E-012	2022-12-10
Microwave log-periodic antenna	SCHWARZBECK	STLP 9149	9149.222	2022-12-10

Remark: " N/A" denotes No Model No. / Serial No. and No Calibration specified.

**4.5.3 TEST PROCEDURE**

The EUT and support equipment, which are placed on a table that is 0.8 meter above ground and the testing was performed in a fully-anechoic chamber.

The testing distance from antenna to the EUT was 3 meters.

The other condition as following manner:

- a. The field strength level was 3V/m.
- b. The frequency range is swept from 80 MHz to 1000 MHz and 1800 MHz, 2600 MHz, 3500 MHz, 5000 MHz, with the signal 80%amplitude modulated with a 1kHz sine wave. The rate of sweep did not exceed 1.5x 10<sup>-3</sup> decade/s. Where the frequency range is swept incrementally, the step size was 1% of fundamental.
- c. The dwell time at each frequency shall be not less than the time necessary for the EUT to be able to respond.
- d. The test was performed with the EUT exposed to both vertically and horizontally polarized fields on each of the four sides.
- e. For the actual test configuration, please refer to the related Item –EUT Test Photos.

**4.5.4 DEVIATION FROM TEST STANDARD**

No deviation

**4.5.5 TEST SETUP**

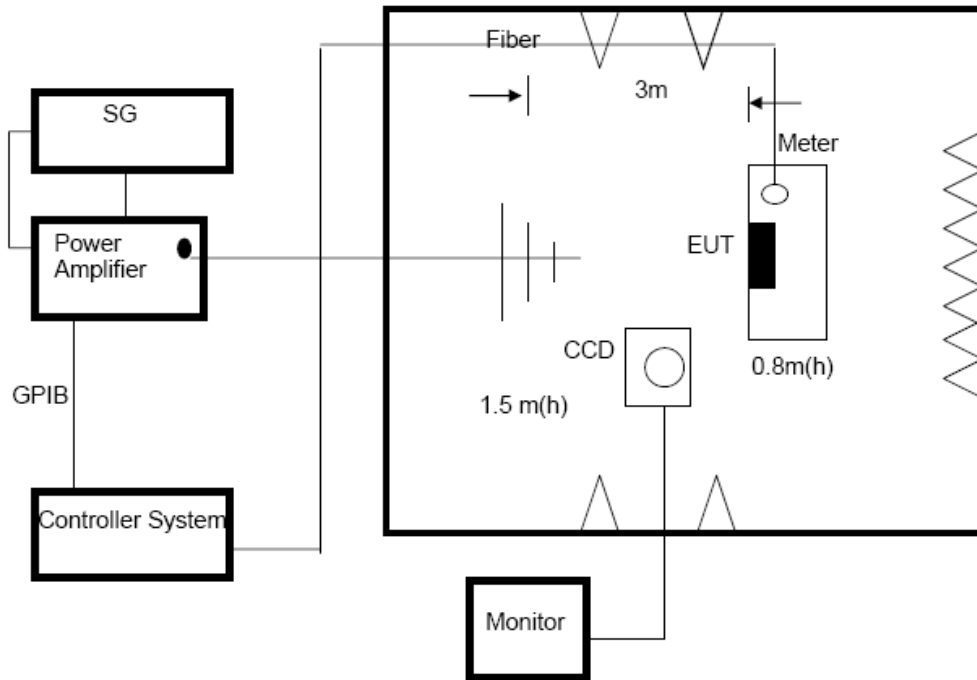

Note:

**TABLE-TOP EQUIPMENT**

The EUT installed in a representative system as described in section 7 of IEC/EN 61000-4-3 was placed on a non-conductive table 0.8 meters in height. The system under test was connected to the power and signal wire according to relevant installation instructions.

**FLOOR-STANDING EQUIPMENT**

The EUT installed in a representative system as described in section 7 of IEC/EN 61000-4-3 was placed on a non-conductive wood support 0.1 meters in height. The system under test was connected to the power and signal wire according to relevant installation instructions.

**4.5.6 TEST RESULTS**

Frequency Range (MHz)	Polarity of Antenna	R.F. Field Strength	Azimuth	Perform. Criteria	Results	Judgment
80MHz - 1000MHz	H / V	3 V/m (rms) AM Modulated 1000Hz, 80%	Front	A	A	PASS
			Rear			
			Left			
			Right			

Frequency Range (MHz)	Polarity of Antenna	R.F. Field Strength	Azimuth	Perform. Criteria	Results	Judgment
1800, 2600, 3500, 5000 MHz	H / V	3 V/m (rms) AM Modulated 1000Hz, 80%	Front	A	A	PASS
			Rear			
			Left			
			Right			

**Note:**

- 1) H/V denotes the Horizontal/Vertical polarity of Antenna.
- 2) N/A - denotes test is not applicable in this test report.
- 3) Criteria A: There was no change operated with initial operating during the test.
- 4) Criteria B: The EUT function loss during the test, but self-recoverable after the test.
- 5) Criteria C: The system shut down during the test.

**4.6 EFT/BURST TESTING**

**4.6.1 TEST SPECIFICATION**

<b>Basic Standard:</b>	IEC/EN 61000-4-4
<b>Required Performance</b>	B
<b>Test Voltage:</b>	Power Line: $\pm 1$ kV
<b>Polarity:</b>	Positive & Negative
<b>Impulse Frequency:</b>	5 kHz
<b>Impulse Wave shape :</b>	5/50 ns
<b>Burst Duration:</b>	15 ms
<b>Burst Period:</b>	300 ms
<b>Test Duration:</b>	Not less than 1 min.

**4.6.2 MEASUREMENT INSTRUMENTS**

Item	Kind of Equipment	Manufacturer	Type No.	Serial No.	Calibrated until
1	Electrical Intelligent Transient Generator	Everfine	EMS61000-4B	G114921CA1341115	2022-05-20

Remark: " N/A" denotes No Model No. / Serial No. and No Calibration specified.

**4.6.3 TEST PROCEDURE**

The EUT and support equipment, are placed on a table that is 0.8 meter above a metal ground plane measured 1m\*1m min. and 0.65mm thick min.

The other condition as following manner:

- a. The length of power cord between the coupling device and the EUT should not exceed 1 meter.
- b. Both positive and negative polarity discharges were applied.
- c. The duration time of each test sequential was 1 minute
- d. For the actual test configuration, please refer to the related Item –EUT Test Photos.

**4.6.4 DEVIATION FROM TEST STANDARD**

No deviation

**4.6.5 TEST SETUP**

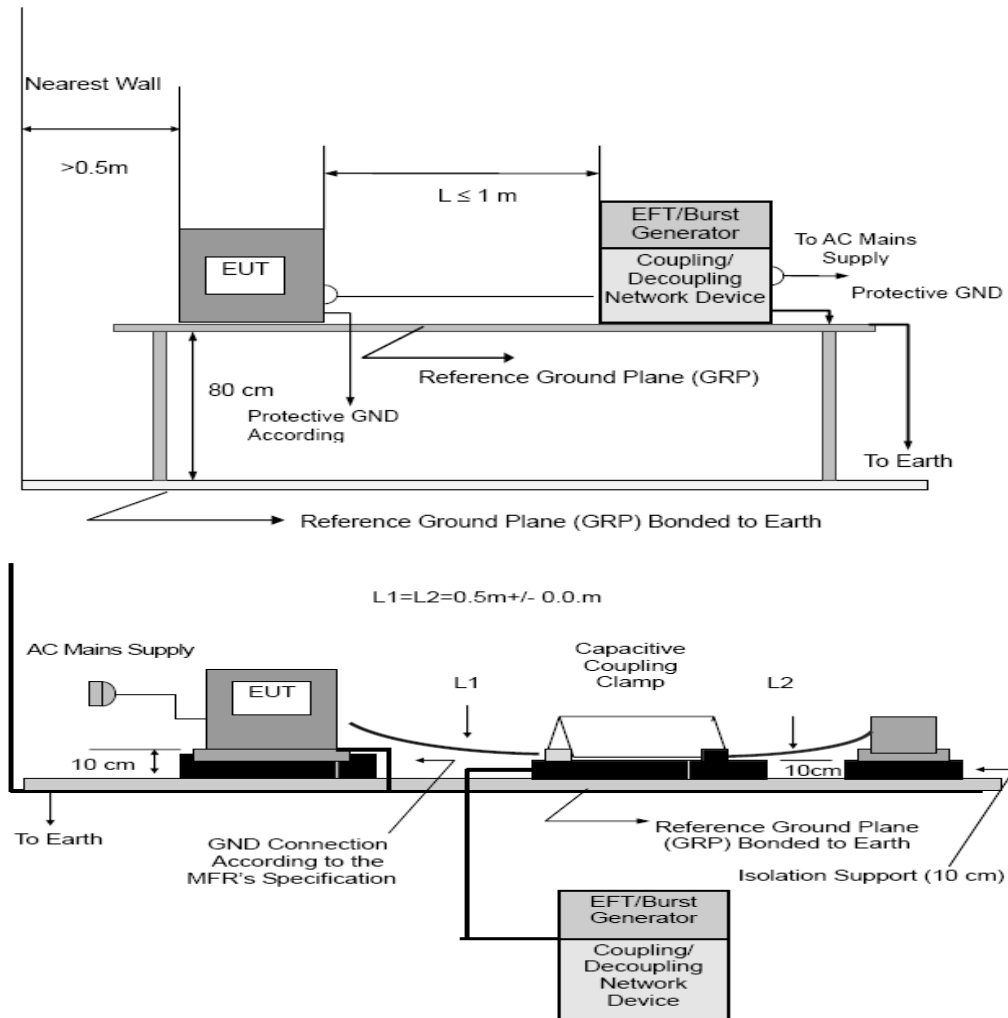

Note:

**TABLE-TOP EQUIPMENT**

The configuration consisted of a wooden table (0.8m high) standing on the Ground Reference Plane. The GRP consisted of a sheet of aluminum (at least 0.25mm thick and 2.5m square) connected to the protective grounding system. A minimum distance of 0.5m was provided between the EUT and the walls of the laboratory or any other metallic structure.

**FLOOR-STANDING EQUIPMENT**

The EUT installed in a representative system as described in section 7 of IEC/EN 61000-4-4 and its cables, were isolated from the Ground Reference Plane by an insulating support that is 0.1-meter thick. The GRP consisted of a sheet of aluminum (at least 0.25mm thick and 2.5m square) connected to the protective grounding system.

**4.6.6 TEST RESULTS**

No applicable the DC product.

**4.7 SURGE TESTING**

**4.7.1 TEST SPECIFICATION**

<b>Basic Standard:</b>	IEC/EN 61000-4-5
<b>Required Performance</b>	B
<b>Wave-Shape:</b>	Combination Wave 1.2/50 us Open Circuit Voltage 8 /20 us Short Circuit Current
<b>Test Voltage:</b>	Power Line: $\pm 0.5KV, \pm 1 KV, \pm 2KV, \pm 4KV,$
<b>Surge Input/Output:</b>	L-N, L-PE, N-PE
<b>Generator Source:</b>	2 ohm between networks
<b>Impedance:</b>	12 ohm between network and ground
<b>Polarity:</b>	Positive/Negative
<b>Phase Angle:</b>	0 /90/180/270
<b>Pulse Repetition Rate:</b>	1 time / min. (maximum)
<b>Number of Tests:</b>	5 positive and 5 negative at selected points

**4.7.2 MEASUREMENT INSTRUMENTS**

Item	Instr.Code	Kind of Equipment	Manufacturer	Type No.	Serial No.	Calibrated until
1	AN-E054	Immunity Teat System	EMC PARTNER	IMU3000 S-T	105684-2060	2022-05-20
2	AN-E055	Signal line coupled decoupling network	EMC PARTNER	CDN-UTP8 ED3	1558	2022-05-20

Remark: " N/A" denotes No Model No. / Serial No. and No Calibration specified.

**4.7.3 TEST PROCEDURE**

- a. For test applied to unshielded unsymmetrically operated interconnection lines of EUT:  
The surge is applied to the lines via the capacitive coupling. The coupling /decoupling networks shall not influence the specified functional conditions of the EUT. The interconnection line between the EUT and the coupling/decoupling networks shall be 2 meters in length (or shorter).
- b. For test applied to unshielded symmetrically operated interconnection /telecommunication lines of EUT:  
The surge is applied to the lines via gas arrestors coupling. Test levels below the ignition point of the coupling arrestor cannot be specified. The interconnection line between the EUT and the coupling/decoupling networks shall be 2 meters in length (or shorter).
- c. For the actual test configuration, please refer to the related Item –EUT Test Photos.

**4.7.4 DEVIATION FROM TEST STANDARD**

No deviation

#### 4.7.5 TEST SETUP

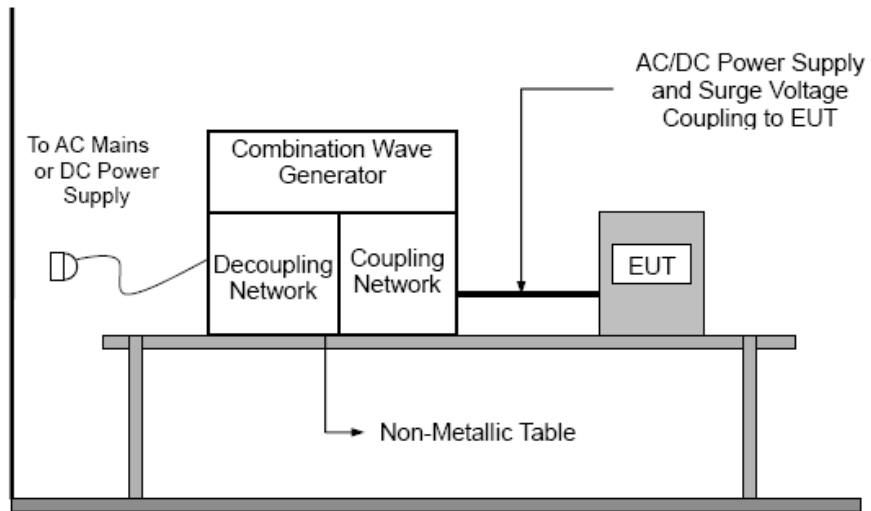

#### 4.7.6 TEST RESULTS

No applicable the DC product.

**4.8 INJECTION CURRENT TESTING**

**4.8.1 TEST SPECIFICATION**

<b>Basic Standard:</b>	IEC/EN 61000-4-6
<b>Required Performance</b>	A
<b>Frequency Range:</b>	3V (rms), 0.15MHz ~ 10MHz; 3V ~1V (rms), 10MHz ~ 30MHz; 1V (rms), 30MHz ~ 80MHz;
<b>Field Strength:</b>	3V (rms), 3V ~1V (rms), 1V (rms)
<b>Modulation:</b>	1kHz Sine Wave, 80%, AM Modulation
<b>Frequency Step:</b>	1 % of fundamental
<b>Dwell Time:</b>	at least 3 seconds

**4.8.2 MEASUREMENT INSTRUMENTS**

Item	Kind of Equipment	Manufacturer	Type No.	Serial No.	Calibrated until
1	CONDUCTED IMMUNITY TEST SYSTEM	FRANKONIA	CIT-10	102D1253	2022-07-21
2	CDN	FRANKONIA	CDN M2+M3	A3011059	2022-08-09
3	Electromagnetic clamp	FRANKONIA	KEMZ-801	21044	2022-08-09

Remark: " N/A" denotes No Model No. / Serial No. and No Calibration specified.

**4.8.3 TEST PROCEDURE**

The EUT and support equipment, are placed on a table that is 0.8 meter above a metal ground plane measured 1m\*1m min. and 0.65mm thick min.

The other condition as following manner:

- a. The field strength level was 3V (rms), 3V ~1V (rms), 1V (rms).
- b. The frequency range is swept from 150 KHz to 80 MHz, with the signal 80%amplitude modulated with a 1kHz sine wave. The rate of sweep did not exceed 1.5x 10<sup>-3</sup> decade/s. Where the frequency range is swept incrementally, the step size was 1% of fundamental.
- c. The dwell time at each frequency shall be not less than the time necessary for the EUT to be able to respond.
- d. For the actual test configuration, please refer to the related Item –EUT Test Photos.

**4.8.4 DEVIATION FROM TEST STANDARD**

No deviation



**4.8.5 TEST SETUP**

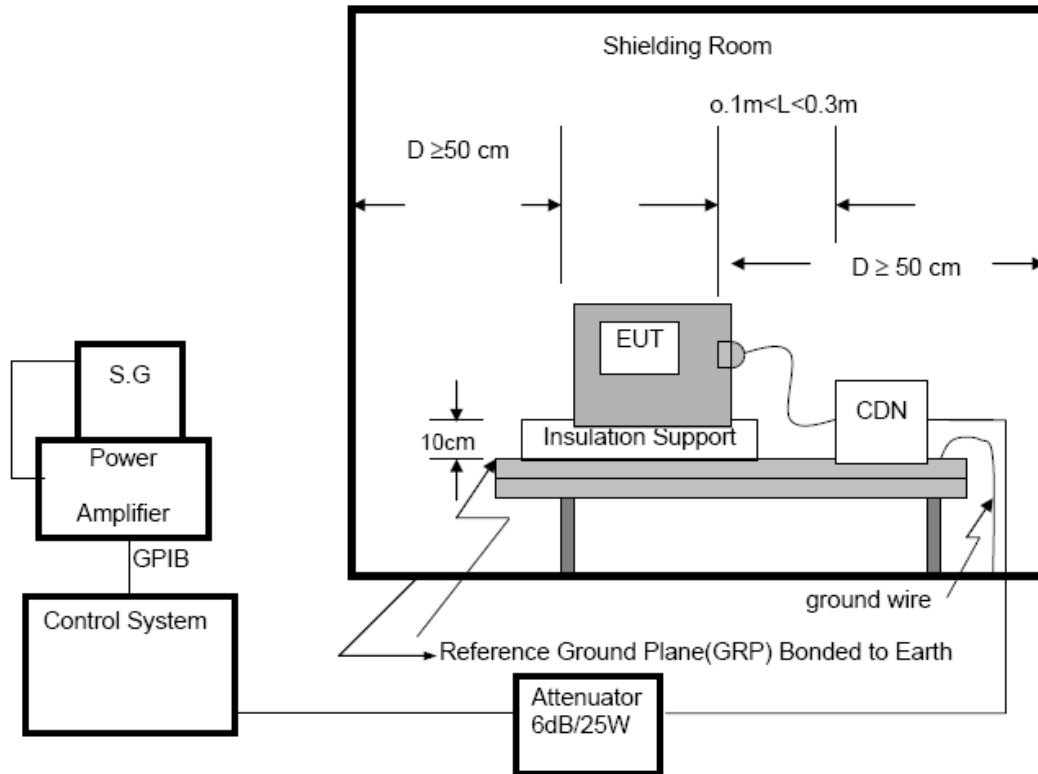

For the actual test configuration, please refer to the related Item –EUT Test Photos.

**NOTE:**

**FLOOR-STANDING EQUIPMENT**

The equipment to be tested is placed on an insulating support of 0.1 meters height above a ground reference plane. All relevant cables shall be provided with the appropriate coupling and decoupling devices at a distance between 0.1 meters and 0.3 meters from the projected geometry of the EUT on the ground reference plane.

**4.8.6 TEST RESULTS**

No applicable the DC product.

**4.9 VOLTAGE INTERRUPTION/DIPS TESTING**

**4.9.1 TEST SPECIFICATION**

<b>Basic Standard:</b>	IEC/EN 61000-4-11
<b>Required Performance:</b>	B (For >95% Voltage Dips) C (For 30% Voltage Dips) C (For >95% Voltage Interruptions)
<b>Test Duration Time:</b>	Minimum three test events in sequence
<b>Interval between Event:</b>	Minimum ten seconds
<b>Phase Angle:</b>	0°
<b>Test Cycle:</b>	3 times

**4.9.2 MEASUREMENT INSTRUMENTS**

Item	Kind of Equipment	Manufacturer	Type No.	Serial No.	Calibrated until
1	Voltage Dips And Interruptions Generator	Everfine	EMS61000-11K	G113317CA8341 117	2022-05-20

Remark: " N/A" denotes No Model No. / Serial No. and No Calibration specified.

**4.9.3 TEST PROCEDURE**

The EUT shall be tested for each selected combination of test levels and duration with a sequence of three dips/interruptions with intervals of 10 s minimum (between each test event). Each representative mode of operation shall be tested. Abrupt changes in supply voltage shall occur at zero crossings of the voltage waveform.

**4.9.4 DEVIATION FROM TEST STANDARD**

No deviation

#### 4.9.5 TEST SETUP

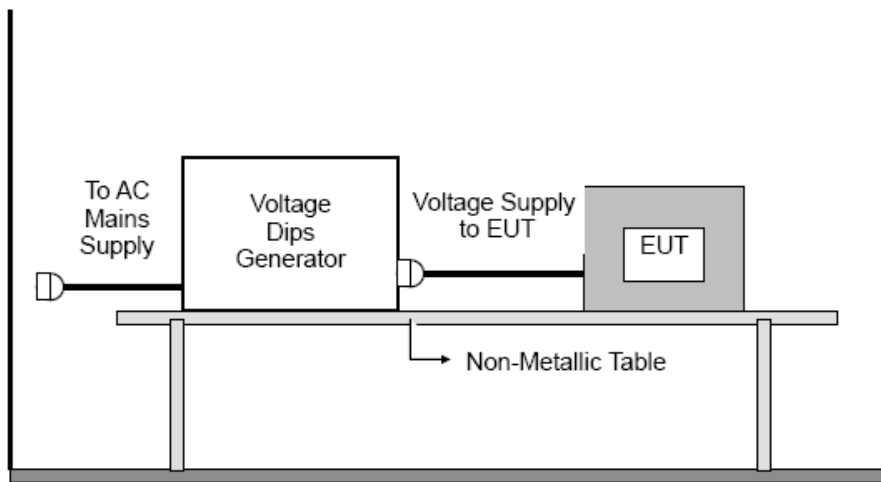

For the actual test configuration, please refer to the related Item –EUT Test Photos.

#### 4.9.6 TEST RESULTS

No applicable the DC product.

**4.10 POWER-FREQUENCY MAGNETIC FILDS**

**4.10.1 MEASUREMENT INSTRUMENTS**

Item	Kind of Equipment	Manufacturer	Type No.	Serial No.	Calibrated until
1	Magnetic Field Tester	EMC-PARTNER	MF1000-1	121	2023-01-21

Remark: " N/A" denotes No Model No. / Serial No. and No Calibration specified.

**4.10.2 TEST LEVEL AND PERFORMANCE CRITERION**

Level	Magnetic Field Strength A/m	Performance criterion
1	1	A

Performance criteria A description: During and after the test the EUT shall continue to operate as intended without operator intervention. No degradation of performance or loss of function is allowed below a minimum performance level specified by the manufacturer when the EUT is used as intended

**4.10.3 TEST PROCEDURE**

The EUT shall be subjected to the test magnetic field by using the induction coil of standard dimensions (1m\*1m) and shown in Section 13.3 The induction coil shall then be rotated by 90 ein order to expose the EUT to the test field with different orientations. .

**4.10.4 DEVIATION FROM TEST STANDARD**

No deviation

**4.10.5 TEST SETUP**

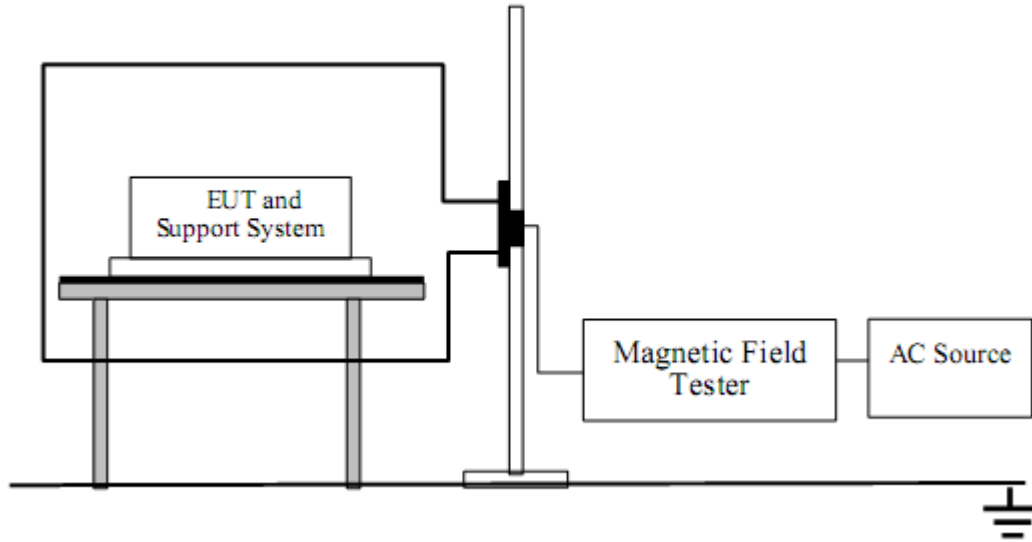

**4.10.6 TEST RESULTS**

N/A

**5. ATTACHMENT**  
5.1 EUT TEST PHOTO

**Radiated Measurement Photo**



**ESD Measurement Photos**



5.2 EUT PHOTO



Figure 1. Overall view of unit



Figure 2. Overall view of unit

\*\*\*\*\* End of Page \*\*\*\*\*